

# Cisco

## Exam 100-105

**Cisco Interconnecting Cisco Networking Devices Part 1 (ICND1  
v3.0)**

Version: 5.0

**[ Total Questions: 239 ]**

**Topic break down**

<b>Topic</b>	<b>No. of Questions</b>
<b>Topic 1: Network Fundamentals</b>	<b>40</b>
<b>Topic 2: LAN Switching Technologies</b>	<b>12</b>
<b>Topic 3: Routing Fundamentals</b>	<b>88</b>
<b>Topic 4: Infrastructure Services</b>	<b>14</b>
<b>Topic 5: Infrastructure Maintenance</b>	<b>46</b>
<b>Topic 6: Simulation</b>	<b>3</b>
<b>Topic 7: Mix Questions</b>	<b>36</b>

Topic 1, Network Fundamentals

Question No : 1 - (Topic 1)

Refer to the exhibit.

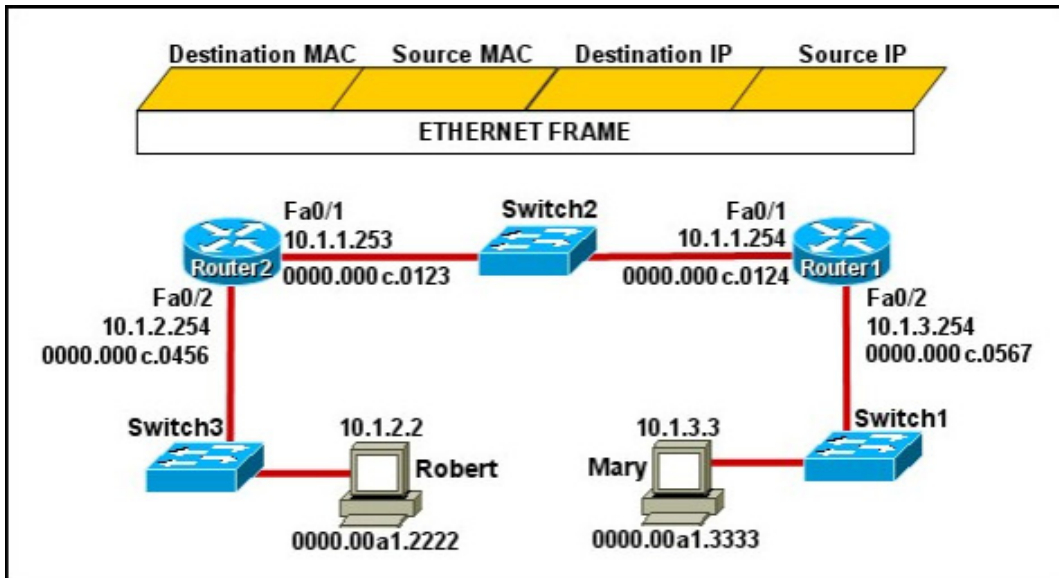

Mary is sending an instant message to Robert. The message will be broken into a series of packets that will traverse all network devices. What addresses will populate these packets as they are forwarded from Router1 to Router2?

A.	<table border="1"> <thead> <tr> <th>Destination MAC</th> <th>Source MAC</th> <th>Destination IP</th> <th>Source IP</th> </tr> </thead> <tbody> <tr> <td>0000.00a1.2222</td> <td>0000.00a1.3333</td> <td>10.1.2.2</td> <td>10.1.3.3</td> </tr> </tbody> </table>	Destination MAC	Source MAC	Destination IP	Source IP	0000.00a1.2222	0000.00a1.3333	10.1.2.2	10.1.3.3
Destination MAC	Source MAC	Destination IP	Source IP						
0000.00a1.2222	0000.00a1.3333	10.1.2.2	10.1.3.3						
B.	<table border="1"> <thead> <tr> <th>Destination MAC</th> <th>Source MAC</th> <th>Destination IP</th> <th>Source IP</th> </tr> </thead> <tbody> <tr> <td>0000.000c.0123</td> <td>0000.000c.0124</td> <td>10.1.2.2</td> <td>10.1.3.3</td> </tr> </tbody> </table>	Destination MAC	Source MAC	Destination IP	Source IP	0000.000c.0123	0000.000c.0124	10.1.2.2	10.1.3.3
Destination MAC	Source MAC	Destination IP	Source IP						
0000.000c.0123	0000.000c.0124	10.1.2.2	10.1.3.3						
C.	<table border="1"> <thead> <tr> <th>Destination MAC</th> <th>Source MAC</th> <th>Destination IP</th> <th>Source IP</th> </tr> </thead> <tbody> <tr> <td>0000.000c.0123</td> <td>0000.000c.0124</td> <td>10.1.1.253</td> <td>10.1.1.254</td> </tr> </tbody> </table>	Destination MAC	Source MAC	Destination IP	Source IP	0000.000c.0123	0000.000c.0124	10.1.1.253	10.1.1.254
Destination MAC	Source MAC	Destination IP	Source IP						
0000.000c.0123	0000.000c.0124	10.1.1.253	10.1.1.254						
D.	<table border="1"> <thead> <tr> <th>Destination MAC</th> <th>Source MAC</th> <th>Destination IP</th> <th>Source IP</th> </tr> </thead> <tbody> <tr> <td>0000.00a1.2222</td> <td>0000.00a1.3333</td> <td>10.1.1.253</td> <td>10.1.1.254</td> </tr> </tbody> </table>	Destination MAC	Source MAC	Destination IP	Source IP	0000.00a1.2222	0000.00a1.3333	10.1.1.253	10.1.1.254
Destination MAC	Source MAC	Destination IP	Source IP						
0000.00a1.2222	0000.00a1.3333	10.1.1.253	10.1.1.254						
E.	<table border="1"> <thead> <tr> <th>Destination MAC</th> <th>Source MAC</th> <th>Destination IP</th> <th>Source IP</th> </tr> </thead> <tbody> <tr> <td>0000.000c.0456</td> <td>0000.000c.0567</td> <td>10.1.2.2</td> <td>10.1.3.3</td> </tr> </tbody> </table>	Destination MAC	Source MAC	Destination IP	Source IP	0000.000c.0456	0000.000c.0567	10.1.2.2	10.1.3.3
Destination MAC	Source MAC	Destination IP	Source IP						
0000.000c.0456	0000.000c.0567	10.1.2.2	10.1.3.3						

- A. Option A
- B. Option B
- C. Option C
- D. Option D
- E. Option E

**Answer: B**

**Explanation:**

The Source and Destination IP address is not going to change. Host 1 IP address will stay as being the source IP and the Host 2 IP address will stay the destination IP address.

Those two are not going to change.

For the MAC address it is going to change each time it goes from one hope to another.

(Except switches... they don't change anything)

Frame leaving HOST 1 is going to have a source MAC of Host 1 and a destination MAC of Router 1.

Router 1 is going to strip that info off and then will make the source MAC address of Router1's exiting interface, and making Router2's interface as the destination MAC address.

Then the same will happen... Router2 is going to change the source/destination info to the

source MAC being the Router2 interface that it is going out, and the destination will be Host2's MAC address.

**Question No : 2 - (Topic 1)**

A workstation has just resolved a browser URL to the IP address of a server. What protocol will the workstation now use to determine the destination MAC address to be placed into frames directed toward the server?

- A. HTTP
- B. DNS
- C. DHCP
- D. RARP
- E. ARP

**Answer: E**

**Explanation:**

The RARP protocol is used to translate hardware interface addresses to protocol addresses. The RARP message format is very similar to the ARP format. When the booting computer sends the broadcast ARP request, it places its own hardware address in both the sending and receiving fields in the encapsulated ARP data packet. The RARP server will fill in the correct sending and receiving IP addresses in its response to the message. This way the booting computer will know its IP address when it gets the message from the RARP server

**Question No : 3 - (Topic 1)**

Which protocol uses a connection-oriented service to deliver files between end systems?

- A. TFTP
- B. DNS
- C. FTP
- D. SNMP

**E. RIP****Answer: C****Explanation:**

TCP is an example of a connection-oriented protocol. It requires a logical connection to be established between the two processes before data is exchanged. The connection must be maintained during the entire time that communication is taking place, then released afterwards. The process is much like a telephone call, where a virtual circuit is established--the caller must know the person's telephone number and the phone must be answered--before the message can be delivered.

TCP/IP is also a connection-oriented transport with orderly release. With orderly release, any data remaining in the buffer is sent before the connection is terminated. The release is accomplished in a three-way handshake between client and server processes. The connection-oriented protocols in the OSI protocol suite, on the other hand, do not support orderly release. Applications perform any handshake necessary for ensuring orderly release.

Examples of services that use connection-oriented transport services are telnet, rlogin, and ftp.

**Question No : 4 - (Topic 1)**

Refer to the exhibit.

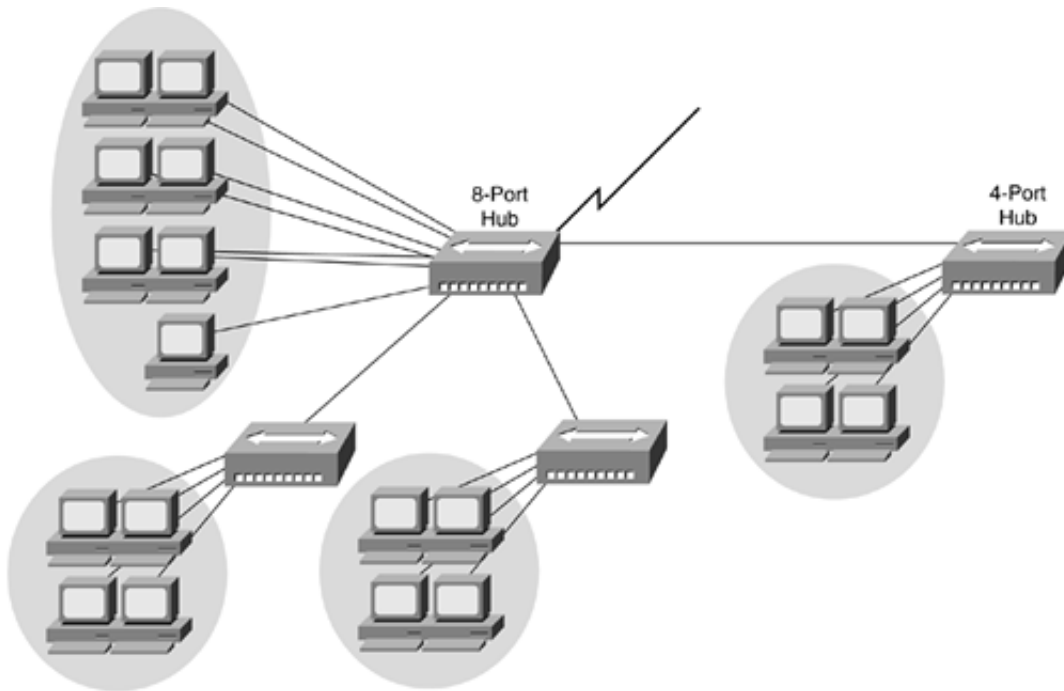

If the hubs in the graphic were replaced by switches, what would be virtually eliminated?

- A. broadcast domains
- B. repeater domains
- C. Ethernet collisions
- D. signal amplification
- E. Ethernet broadcasts

**Answer: C**

**Explanation:**

Modern wired networks use a network switch to eliminate collisions. By connecting each device directly to a port on the switch, either each port on a switch becomes its own collision domain (in the case of half duplex links) or the possibility of collisions is eliminated entirely in the case of full duplex links.

**Question No : 5 - (Topic 1)**

Refer to the exhibit.

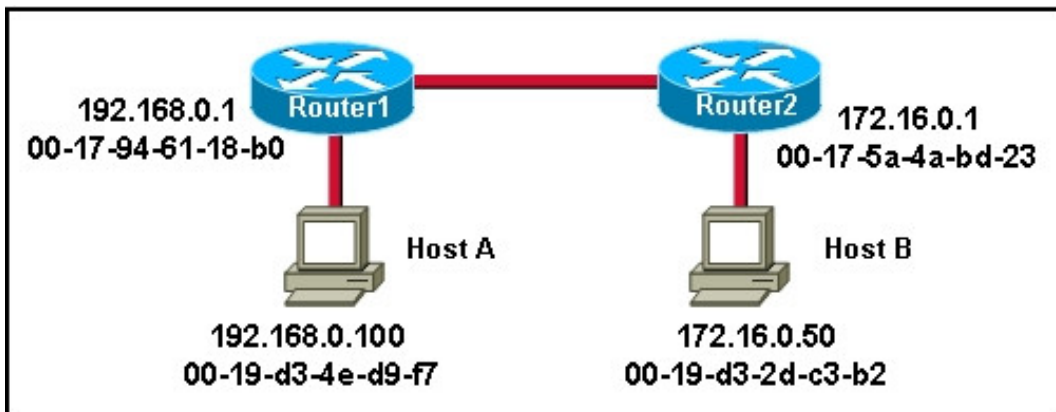

Host A is sending a packet to Host B for the first time. What destination MAC address will Host A use in the ARP request?

- A. 192.168.0.1
- B. 172.16.0.50
- C. 00-17-94-61-18-b0
- D. 00-19-d3-2d-c3-b2
- E. ff-ff-ff-ff-ff-ff
- F. 255.255.255.255

**Answer: E**

**Explanation:**

For the initial communication, Host A will send a broadcast ARP (all F's) to determine the correct address to use to reach the destination.

ARP sends an Ethernet frame called an ARP request to every host on the shared link-layer legmen. The Ethernet header includes the source host MAC address and a destination address of all Fs representing a broadcast frame. The ARP request contains the sender's MAC and IP address and the target (destination) IP address. The target's MAC address is set to all 0s.

ARP Request

Reference:

<http://www.technicalhowto.com/protocols/arp/arp.html>

**Question No : 6 - (Topic 1)**



Refer to the exhibit.

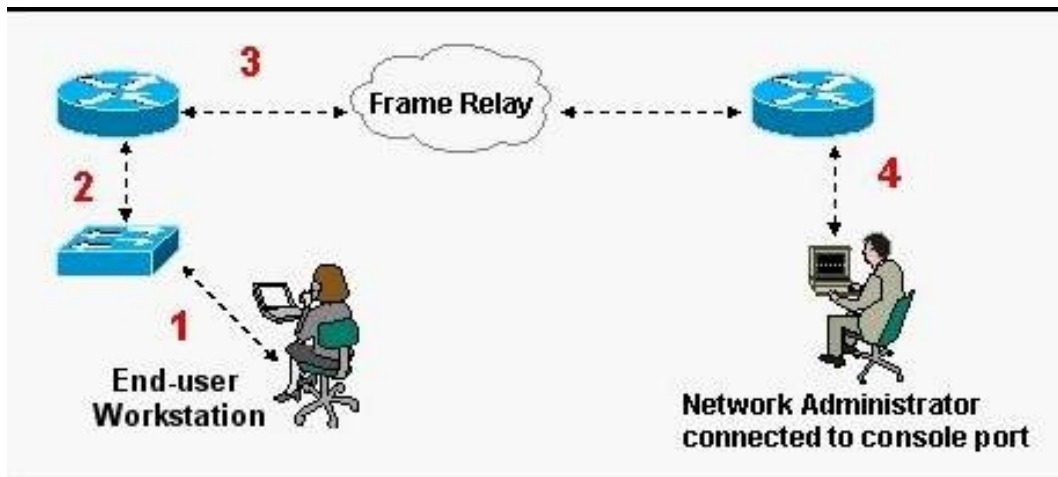

What kind of cable should be used to make each connection that is identified by the numbers shown?

- A.** 1 - Ethernet Crossover cable  
2 - Ethernet straight-through cable  
3 - Fiber Optic cable  
4 - Rollover cable
- B.** 1 - Ethernet straight-through cable  
2 - Ethernet straight-through cable  
3 - Serial cable  
4 - Rollover cable
- C.** 1 - Ethernet rollover cable  
2 - Ethernet crossover cable  
3 - Serial cable  
4 - Null-modem cable
- D.** 1 - Ethernet straight-through cable  
2 - Ethernet Crossover cable  
3 - Serial cable  
4 - Rollover cable
- E.** 1 - Ethernet straight-through cable  
2 - Ethernet Crossover cable  
3 - Serial cable  
4 - Ethernet Straight-through cable

**Answer: B**

**Explanation:**

When connecting a PC to a switch, a standard Ethernet straight through cable should be used. This same cable should also be used for switch to router connections. Generally

speaking, crossover cables are only needed when connecting two like devices (PC-PC, switch-switch, router-router, etc).

Routers connect to frame relay and other WAN networks using serial cables.

Rollover cables are special cables used for connecting to the console ports of Cisco devices.

**Question No : 7 - (Topic 1)**

Refer to the exhibit.

```
SwitchA# show mac-address-table
< non-essential output omitted >
```

Destination Address	Address Type	VLAN	Destination Port
00b0.d056.fe4d	Dynamic	1	FastEthernet0/3
00b0.d043.ac2e	Dynamic	1	FastEthernet0/4
00b0.d0fe.ac32	Dynamic	1	FastEthernet0/5
00b0.d0da.cb56	Dynamic	1	FastEthernet0/6

**Frame received by SwitchA:**

Source MAC	Destination MAC	Source IP	Destination IP
00b0.d056.fe4d	00b0.d0da.cb56	192.168.40.5	192.168.40.6

SwitchA receives the frame with the addressing shown. According to the command output also shown in the exhibit, how will SwitchA handle this frame?

- A. It will drop the frame.
- B. It will forward the frame out port Fa0/6 only.
- C. It will flood the frame out all ports.
- D. It will flood the frame out all ports except Fa0/3.

**Answer: B**

**Explanation:**

Switches keep the learned MAC addresses in a table, so that when a frame comes in with a destination MAC address that the switch has already learned, it will forward it to that port